



*Diamond Blue*  
*Ampeg* CLASSIC

**MODEL B-200R**



**USER'S GUIDE**



**Table of Contents:**

**Introduction**.....3

**The Front Panel** .....4,5

**Important Information About Tubes and Tube Products**

**A Brief History Of The Tube**.....6

**Preamp Tube Types and Usage**.....7

**The Nature of Tubes: Why (and When) to Replace Them** .....8

**Survival Tips For Tube Amplifiers**.....9

**System Block Diagram**.....10

**Technical Specifications** .....back cover

<b>CAUTION</b> RISK OF ELECTRIC SHOCK DO NOT OPEN	<b>PRECAUCION</b> RIESGO DE CORRIENTAZO NO ABRA	<b>ATTENTION</b> RISQUE D'ELECTROCUTION NE PAS OUVRIR
WARNING: TO REDUCE THE RISK OF FIRE OR ELECTRIC SHOCK, DO NOT EXPOSE THIS APPARATUS TO RAIN OR MOISTURE. TO REDUCE THE RISK OF ELECTRIC SHOCK, DO NOT REMOVE COVER. NO USER-SERVICEABLE PARTS INSIDE. REFER SERVICING TO QUALIFIED SERVICE PERSONNEL.	PRECAUCION: PARA REDUCIR EL RIESGO DE INCENDIOS O DESCARGAS ELECTRICAS, NO PERMITA QUE ESTE APARATO QUEDE EXPUESTO A LA LLUVIA O LA HUMEDAD. PARA DISMINUIR EL RIESGO DE CORRIENTAZO NO ABRA LA CUBIERTA. NO HAY PIEZAS ADENTRO QUE EL USUARIO PUEDE REPARAR DEJE TODO MANTENIMIENTO A LOS TECNICOS CALIFICADOS.	ATTENTION: PROTEGEZ CET APPAREIL DE LA PLUIE ET DE L'HUMIDITE AFIN D'EVITER TOUT RISQUE D'INCENDIE OU D'ELECTROCUTION. POUR REDUIRE D'ELECTROCUTION NE PAS ENLEVER LE COUVERCLE. AUCUNE PIECE INTERNE N'EST REPRABLE PAR L'UTILISATEUR. POUR TOUTE REPARATION, S'ADRESSER A UN TECHNICIEN QUALIFIE.

**IMPORTANT SAFETY INSTRUCTIONS**

- READ, FOLLOW, HEED, AND KEEP ALL INSTRUCTIONS AND WARNINGS.
- DO NOT OPERATE NEAR ANY HEAT SOURCE AND DO NOT BLOCK ANY VENTILATION OPENINGS ON THIS APPARATUS. FOR PROPER OPERATION, THIS UNIT REQUIRES 3" (75mm) OF WELL VENTILATED SPACE AROUND HEATSINKS AND OTHER AIR FLOW PROVISIONS IN THE CABINET.
- DO NOT USE THIS APPARATUS NEAR SPLASHING, FALLING, SPRAYING, OR STANDING LIQUIDS.
- CLEAN ONLY WITH LINT-FREE DAMP CLOTH AND DO NOT USE CLEANING AGENTS.
- ONLY CONNECT POWER CORD TO A POLARIZED, SAFETY GROUNDED OUTLET WIRED TO CURRENT ELECTRICAL CODES AND COMPATIBLE WITH VOLTAGE, POWER, AND FREQUENCY REQUIREMENTS STATED ON THE REAR PANEL OF THE APPARATUS.
- PROTECT THE POWER CORD FROM DAMAGE DUE TO BEING WALKED ON, PINCHED, OR STRAINED.
- UNPLUG THE APPARATUS DURING LIGHTNING STORMS OR WHEN UNUSED FOR LONG PERIODS OF TIME.
- ONLY USE ATTACHMENTS, ACCESSORIES, STANDS, OR BRACKETS SPECIFIED BY THE MANUFACTURER FOR SAFE OPERATION AND TO AVOID INJURY.
- WARNING: TO REDUCE THE RISK OF ELECTRIC SHOCK OR FIRE, DO NOT EXPOSE THIS UNIT TO RAIN OR MOISTURE.
- SERVICE MUST BE PERFORMED BY QUALIFIED PERSONNEL.
- OUR AMPLIFIERS ARE CAPABLE OF PRODUCING HIGH SOUND PRESSURE LEVELS. CONTINUED EXPOSURE TO HIGH SOUND PRESSURE LEVELS CAN CAUSE PERMANENT HEARING IMPAIRMENT OR LOSS. USER CAUTION IS ADVISED AND EAR PROTECTION IS RECOMMENDED IF UNIT IS OPERATED AT HIGH VOLUME.
- WARNING: THIS UNIT REQUIRES A SAFETY GROUNDED OUTLET WIRED TO CURRENT ELECTRIC CODES HAVING THE LINE SUPPLY VOLTAGE, POWER, AND FREQUENCY IDENTIFIED ON THE REAR OF THE UNIT. THE OUTLET MUST REMAIN ACCESSIBLE TO DISCONNECT THE UNIT IF A FAULT SHOULD ARISE WHILE IN USE. THIS UNIT SHOULD BE UNPLUGGED WHEN NOT IN USE.

EXPLANATION OF GRAPHICAL SYMBOLS: EXPLICACION DE SIMBOLOS GRAFICOS: EXPLICATION DES SYMBOLES GRAPHIQUES:	= "DANGEROUS VOLTAGE" "VOLTAJE PELIGROSO" "DANGER HAUTE TENSION"	= "IT IS NECESSARY FOR THE USER TO REFER TO THE INSTRUCTION MANUAL" "ES NECESARIO QUE EL USUARIO SE REFIERA AL MANUAL DE INSTRUCCIONES." "REFERREZ-VOUS AU MANUAL D'UTILISATION"
--	---	---



**Introduction:**

*Thank you for selecting the Ampeg Rocket Bass amplifier. Inspired by the classic Ampeg bass amps of the sixties, this easy-to-use amplifier represents Ampeg's quest to provide you the finest instrument amplification systems available. In order to get the most out of your new amplifier, please read this user's guide prior to its use.*

# *Ampeg* MODEL B-200B

## The Front Panel:

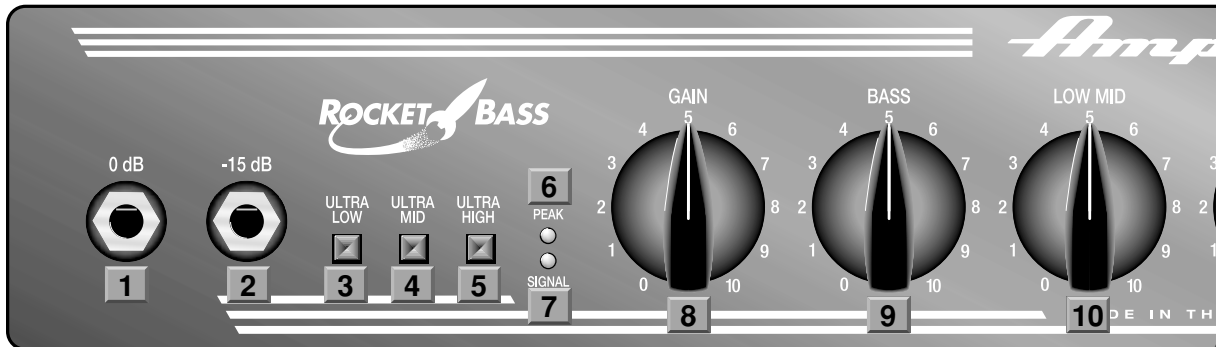

**1. 0dB Input** accepts a standard 1/4" instrument plug from your bass. This input is suited for use with instruments that have passive electronics.

**2. -15dB Input** accepts a standard 1/4" instrument plug from high output basses. This input is padded 15dB to compensate for higher output sources and is suited for use with basses that have active electronics or high output pickups.

**3. Ultra Low** increases the low frequency output by 7dB at 40Hz. This adds to the rumble and overall feel of the low bass notes.

**4. Ultra Mid** decreases the mid frequency output by 6dB at 600Hz. This removes some of the middle frequencies for a "contoured" sound.

**5. Ultra High** increases the high frequency output by 7dB at 5kHz. This adds crispness to your sound.

**6. Peak LED** illuminates when the Gain control (#8) is set too high. This indicates overdriving of the preamplifier which causes clipping. (See the Gain control, #8.)

**7. Signal LED** illuminates when the Gain control (#8) is adjusted properly. (See the text for the Gain control.)

**8. Gain** must be adjusted to match the output of your instrument to the amplifier. For the proper setting, turn on the amplifier, rotate the Gain control and the Master control (#13) fully counter clockwise and begin playing your bass. Rotate the Gain control clockwise until the Signal LED (#7) illuminates while playing and the Peak LED (#6) flashes occasionally.

**9. Bass** adjusts the output level of the low frequencies and offers a cut or boost of 12dB at 70Hz.

**10. Low Mid** adjusts the output level of the lower midrange frequencies and offers a cut or boost of 12dB at 300Hz.

**11. High Mid** adjusts the output level of the upper midrange frequencies and offers a cut or boost of 11dB at 1.5kHz.

**12. Treble** adjusts the output level of the high frequencies and offers a cut or boost of 14dB at 7kHz.

# *Ampeg* MODEL B-200B



**13. Master** controls the overall output level of the amplifier.

**14. XLR Line Out** supplies a mono line level signal for connecting to a mixing console, tape recorder or external amplifier. The signal at this jack is pre-Master and post-EQ.

**15. Phones** allows the connection of a pair of stereo headphones for private practice sessions. The internal speaker is disconnected whenever headphones are used.

**16. Line Out / Phones** adjusts the output level of the signal at the XLR Line Out jack (#14) and the signal level at the Phones jack (#15).

**17. Power light** indicates the amplifier is turned on by glowing an iridescent blue color.

**18. Power switch** is used to turn the amplifier on and off.

**19. Power cord (rear panel, not shown)** connects the amplifier to a suitable source of A.C. voltage. The grounded power cord should only be plugged into a grounded power outlet that meets all applicable electrical codes and is compatible with the voltage, power and frequency requirements stated on the rear panel. **Do not attempt to defeat the safety grounding connection!**



## **Important Information About Tubes and Tube Products:**

### **A Brief History Of The Tube:**

In 1883, Edison discovered that electrons would flow from a suspended filament when enclosed in an evacuated lamp. Years later, in 1905, Fleming expanded on Edison's discovery and created the "Fleming Valve". Then, in 1907, Dr. Lee de Forest added a third component – the grid – to the "Fleming's Valve" and the vacuum tube was a fact of life. The door to electronic amplification was now open.

During World War II, data gleaned from their intensive research on the detectors used in radar systems led Bell Telephone Laboratories to the invention of the transistor. This reliable little device gained quick support as the new component for amplification. The death of the vacuum tube seemed imminent as designers, scientists, and engineers reveled in the idea of replacing large, fragile glass tubes with these small, solid-state devices.

However, there were (and still are) many serious listeners who realized that the sound produced by a "transistor" amplifier is significantly different from that produced by a tube amplifier with identical design specifications. They considered the sound produced by these new solid-state devices to be hard, brittle, and lifeless. It was determined that solid-state devices produced a less musical set of harmonics than tubes. When pushed past their limits, they tend to mute the tone and emphasize the distortion.

Tubes, on the other hand, produce a more musical set of harmonics, the intensity of which can be controlled by the player. This characteristic adds warmth and definition to the sound which has become the hallmark of tube amplifiers. When tubes are driven into clipping, the harmonic overtones can be both sweet and pleasing or intense and penetrating, depending on the musician's musical taste and playing technique.

Over the years, application engineers have designed a number of outstanding solid-state amplifiers that sound very, very good. Some use special circuitry which enables them to simulate the distortion characteristics of a tube amplifier. However, the tube amplifier, still held in the highest esteem by many musicians, offers a classic "vintage" sound in a contemporary market.



## **Important Information About Tubes and Tube Products (continued):**

### **Preamp Tube Types And Usage:**

The tubes used in the preamplifier (12AX7, 12AU7, 12AT7, etc.) amplify the signal from your instrument and shape the sound. They are inherently microphonic (mechanically pick up and transmit external noises). Since these tubes are used in the critical first stages of a tube amplifier's circuitry, it is very important to use high-quality, low noise/low microphonic tubes for this application. Although tubes of this quality may be difficult to find and typically cost more than "off-the-shelf" tubes, the improvement in performance is worth the investment.



## **Important Information About Tubes and Tube Products (continued):**

### **The Nature Of Tubes: Why (And When) To Replace Them:**

Tubes are made up of a number of fragile mechanical components that are vacuum-sealed in a glass envelope or bubble. The tube's longevity is based on a number of factors which include how hard and often the amplifier is played, vibration from the speakers, road travel, repeated set up and tear down, etc.

If your amplifier squeals, makes noise, loses gain, starts to hum, lacks "sensitivity," or feels as if it is working against you, the preamp tube may need to be replaced. Remember to use only high quality, low microphonic tubes.

If you're on the road a lot, we recommend that you carry replacement tubes.



## **Important Information About Tubes and Tube Products (continued):**

### **Survival Tips For Tube Amplifiers:**

To prolong tube life, observe these tips and recommendations:

- After playing the amplifier, allow sufficient time for it to properly cool down prior to moving it. A properly cooled amplifier prolongs tube life due to the internal components being less susceptible to the damage caused by vibration.
- Allow the amplifier to warm up to room temperature before turning it on. The heat generated by the tube elements can crack a cold glass housing.
- Protect the amplifier from dust and moisture. If liquid gets into the amplifier proper, or if the amplifier is dropped or otherwise mechanically abused, have it checked out at an authorized service center before using it.
- Proper maintenance and cleaning in combination with routine checkups by your authorized service center will insure the best performance and longest life from your amplifier.

***CAUTION: Tube replacement should be performed only by qualified service personnel who are familiar with the dangers of hazardous voltages that are typically present in tube circuitry.***

# *Ampex MODEL B-200B*

## System Block Diagram:

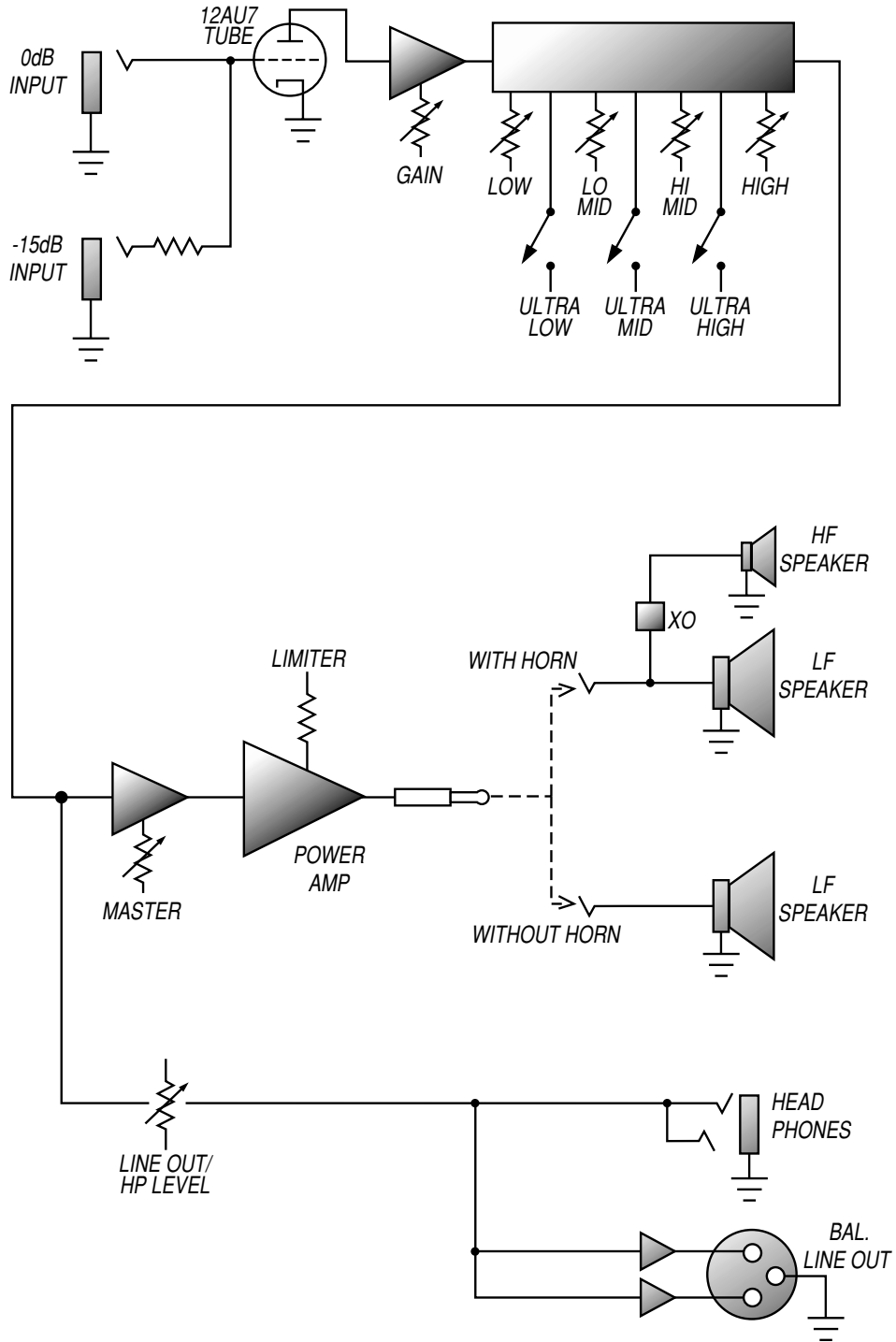



**Declaration of Conformity**

**Manufacturer's Name:** SLM Electronics  
**Corporate Headquarters:** 1901 Congressional Drive, St. Louis, Missouri 63146  
**Primary Production Facility:** 700 Hwy 202 W, Yellville, Arkansas, 72687

**Product Type:** Audio Amplifier

**Products meet the regulations for compliance marking under:**

ETL standards UL6500, UL60065, or UL813  
CSA standards E60065 or C22.2 No.1-M90  
CE safety standard EN60065  
CE EMC standards EN55103 or EN55013 and EN61000  
FCC standards 47CFR 15.107 and 15.109 Class A  
C-tick designation Level 2, ABN #56748810738, ARBN# N222  
KETI standard K60065 (limited model approval)

Compliance Support Contact: SLM Electronics, Attn: R&D Compliance Engineer  
1901 Congressional Drive, St Louis, Missouri, 63146 • Tel.: 314-569-0141, Fax: 314-569-0175

# *Ampeg MODEL B-200R*

## **B-200R TECHNICAL SPECIFICATIONS:**

<b>OUTPUT POWER RATING</b>	220 Watts RMS, 4 ohm load, 5% THD, 120 VAC
<b>SIGNAL TO NOISE RATIO</b>	70dB Typical
<b>POWER REQUIREMENTS</b>	120 VAC, 60 Hz, 320VA 100/120 VAC, 50/60 Hz, 320VA 230 VAC, 50/60 Hz, 320VA
<b>GAIN</b>	38 dB
<b>ULTRA LOW</b>	+7dB @ 40Hz
<b>ULTRA MID</b>	-6dB @ 600Hz
<b>ULTRA HIGH</b>	+7dB @ 5kHz
<b>BASS</b>	±12dB @70Hz
<b>LOW MID</b>	±12dB @300Hz
<b>HIGH MID</b>	±11dB @1.5kHz
<b>TREBLE</b>	±14dB @7kHz
<b>PREAMP TUBE</b>	(1) 12AU7
<b>SPEAKER SPECS</b>	15", 250 w, 4 ohm, 2.5" voice coil dia., 56 oz. magnet 1" High Efficiency Piezo tweeter
<b>SIZE AND WEIGHT</b>	22.25" W x 22.5" H x 14.25" D 69 lbs.

*Ampeg continually develops new products, as well as improves existing ones. For this reason, the specifications and information in this manual are subject to change without notice..*



[www.amepeg.com](http://www.amepeg.com)

*Ampeg is proudly Made in America.*

©2005 SLM Electronics, 1400 Ferguson Avenue, St. Louis, MO 63133 U.S.A.



P/N 47-436-01 • 111005